

Celtic Moon Stage Plot

Mixer: Behringer Air XR-18 digital mixer. **Needs electricity.** Plus iPad Pro for mixer control. **(needs electricity or charger)**

2 Powered Speakers: Bose L1 Pro16s **(need electricity)**

2 Powered Monitors: Bose S1 Pro floor monitor **(needs electricity)**

Verlene (6-7 inputs needed)

1. Harp: integrated pickup into SansAmp into XLR out to mixer
 2. Guitar: integrated pickup into LR Baggs DI into XLR out to mixer
 3. Mandolin: KNA contact pickup into SansAm DI into XLR out to mixer
 4. **or** Tenor Banjo: Meyers pickup SansAmp DI into XLR out to mixer
 5. Nyckelharpa: KNA contact pickup into LR Baggs DI into XLR out to mixer
 6. Violin: integrated pickup into LR Baggs DI into XLR out to mixer
 7. Vocal Mic: AKG C636 **(needs phantom power)**, XLR out to mixer
- Concertina: Acoustic – no need for amplification

Lynda (6 inputs needed)

1. Vocal Mic: AKG C636 **(needs phantom power)**, XLR out to mixer
 2. Celtic Harp: Integrated pick-up into Sans amp, XLR out to mixer
 3. Stage Piano: Roland FP-90x into Sans Amp, 1/4" out to mixer. **Needs electricity**
 4. Guitar: Taylor acoustic with pick-up into DI box, XLR out to mixer
 5. Wazinator
 6. Drum machine **Needs electricity:** 1/4" out to mixer
- Melodica: Acoustic harmonica-like keys (played into mic)

Large venue stage plot with both Bose and monitor:

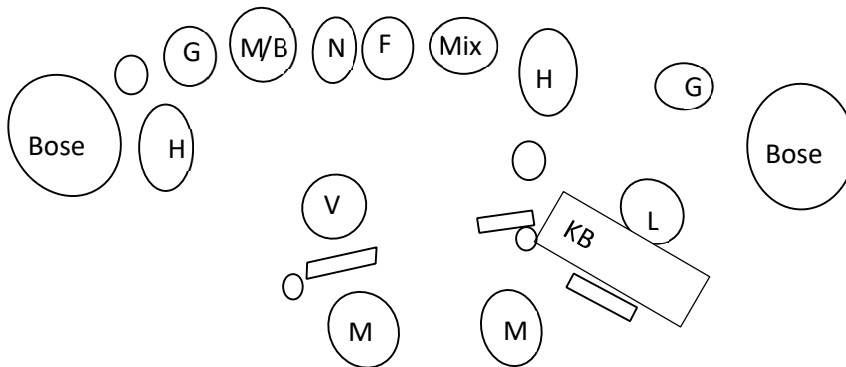

Small venue stage plot with just one Bose for mains and monitor:

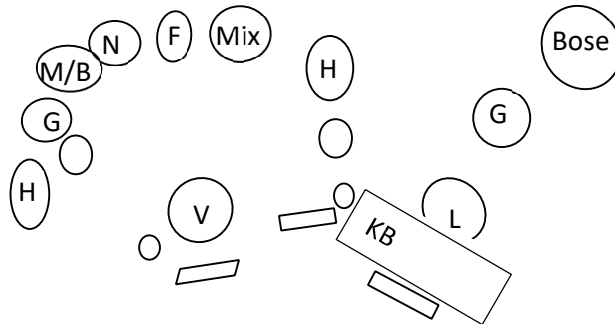

Large empty circles are our harp chairs, small are mike stands. We would move our harps and chairs forward to play.

Channels on mixer:

1. Verlene's harp
2. Verlene's guitar
3. mandolin
4. banjo
5. nyckelharpa
6. violin
7. Verlene Vox
8. Lynda Vox
9. Lynda's Harp
10. Keyboard
11. Lynda's Guitar
12. Wazinator
13. Drum machine